

Morgan Spa

Owner's Manual

Operation and Care For Your Spa

OVER 35 YEARS
IN BUSINESS

Spas manufactured between:
January 1999 to January 2000

Disclaimer:

The information in this manual is accurate to the best of Morgan Buildings and Spas, Inc.'s knowledge. However, Morgan assumes no responsibility for errors or omissions. Nor is any liability assumed for damages resulting from use of the information contained herein.

Congratulations on your purchase of a Morgan Spa. Your Owner's Manual provides installation, operation and maintenance instructions. Please review it and keep it for future reference.

Owner's Record Information

Date Purchased _____

Purchased From _____

Installed By _____

Serial Number _____ Model _____

Corporate Office: Morgan Buildings & Spas, Inc., P. O. Box 660280, Dallas, Texas
75266-0280 (972) 864-7300

REVISED: February 2, 1999 (Section 2/w-Activation)

TABLE OF CONTENTS

SECTION 1: INSTALLATION & SAFETY INSTRUCTIONS

a.	Introduction	1
b.	Important Safety Instructions	1
c.	A Word About Spa Fun & Safety	3
d.	Spa Location	3
e.	Spa Accessories	4
f.	Warning...For Your Safety	5
g.	Field Wiring Diagram - 120/240V Convertible	6
h.	Field Wiring Diagram - 240V	7
i.	Initial Fill & Startup	8

SECTION 2: Morgan Digital Control Systems

a.	Start the Pump	9
b.	Start the Blower	9
c.	Turn on the Light	9
d.	Changing the Water Temperature	9
e.	Activate the Standby Mode	10
f.	Programming	10
g.	Problems & Corrective Actions	10

SECTION 3: MORGAN II DELUXE DIGITAL SINGLE PUMP & DUAL PUMP CONTROL SYSTEM

a.	Pump Switch for 1-Pump System	12
b.	Pump Switch for 2-Pump System	12
c.	Up & Down Keypad	13
d.	Quiet/Stand-by Mode	13
e.	Blower Keypad	13
f.	Light Keypad	13
g.	Panel Lock	13
h.	Program Keypad	13
i.	To Unlock Keypad	14
j.	Economy Keypad	14
k.	Other Features:	14
1.	Alternating Temperature/Time Display	14
2.	Side-Panel	14
3.	Ozone Output	15
4.	High Limit	15
5.	Pressure Switch	15
6.	Smart Winter Mode	15
7.	Power-Up Detection	15
8.	Temperature Sensor Failure	15
l.	Trouble Shooting Guide	16

SECTION 4: AIR CONTROLS & JETS

a.	Air Controls	17
b.	Total Turbo Valve	17
c.	Power Collar Valve	17
d.	Water Flow Control Valve	17
e.	Cyclone Jet	18
f.	Ultramassage Luxury Jet	18
g.	Flutter Blaster Jet	18
h.	Mini Luxury Jet	18

i.	Mini Flutter Blaster Jet	18
j.	Non-Adjustable Directional Euro Jet & Ozone Jet	18
k.	Non-Adjustable Pulsator Euro Jet	18
l.	Air Injector Jet	19
m.	Air Action Jet	19
n.	Neck Jet	19
o.	Swirlpool Jet	19
p.	Divertor Valve	19
q.	Mastermassage Jet	19

SECTION 5: MAINTAINING YOUR PORTABLE SPA & PROTECTING YOUR SPA IN WINTER MONTHS

a.	Recommended Maintenance Schedule for Your Spa	20
b.	Cleaning & Changing Filter Cartridge	20
c.	How to Drain & Clean Your Spa	21
d.	Care & Upkeep of Your Spa	21
	1. The Redwood Cabinet	21
	2. Acrylic Finish	21
	3. Spa Cover	22
	4. Decks	22
e.	Protecting Your Spa in Winter Months	22
f.	Moving Your Spa	22

SECTION 6: CHEMICALS

a.	The Spa Frog Mineral Purifier	
	1) What Is It?	23
	2) How It Works	23
	3) Spa Start-Up	23
	4) Regular Spa Care	23
b.	The Importance of Chemical Balance	24
c.	A Simple Overview of Spa Chemistry & Disinfecting	24
d.	The Importance of pH Control	24
e.	Trouble Shooting Guide	25

SECTION 7: OZONATORS

a.	Your Ozone Generator	27
b.	Some of the Benefits of Using Ozone	27
c.	Spa Maintenance With Ozone	27
d.	Trouble Shooting Guide	28

SECTION 8: GLOSSARY OF TERMS

29

SECTION 9: SCHEMATICS (ALL POWER PACKS)

a.	Single Pump / Dual Pump 240	31
b.	120 / 240 Convertible Pack	32
c.	220V Pack No Blower	33

SECTION 1 Installation and Safety Instructions

Introduction

Your Morgan spa incorporates the finest components available, assembled in a manner designed to provide maximum enjoyment, ease of operation and years of trouble-free service.

Please read your owner's manual very carefully and thoroughly. Keep it in an easily-accessible place, so you are able to refer to it whenever you use your spa. The following pages contain complete, detailed instructions and precautions regarding the use, care and maintenance.

IMPORTANT SAFETY INSTRUCTIONS FOR ELECTRICAL EQUIPMENT

When installing and using this electrical equipment, basic safety precautions should always be followed including the following:

1. READ AND FOLLOW INSTRUCTIONS.

2. **WARNING**-To reduce the risk of injury, do not permit children to use this product unless they are closely supervised.

3. A wire connector is provided on this unit to connect a minimum NO. 8 AWG solid copper conductor between this unit and any metal equipment, metal enclosures of electrical equipment, metal water pipe, or conduit within 5 feet (1.5m) of the unit.

4. **DANGER**-Risk of Injury
A. Replace damaged cord immediately.
B. Do not bury cord.
C. Connect to a grounded, grounding type receptacle only.

5. **WARNING**-All 120V models are provided with a ground fault circuit interrupter located on the power cord. The GFCI must be tested before each use. Connect the plug to the power supply, and with unit operating, push the test button. The unit should stop operating and the reset button should appear. Push the reset button. The unit should now operate normally. If the interrupter fails to operate in this manner, there is a ground current flowing indicating the possibility of an electric shock. Disconnect the plug from the receptacle until the source of the breakdown has been identified and corrected.
NOTE: This only applies to 120V operated spas.

6. **DANGER**-Risk of Accidental Drowning. Extreme caution must be exercised to prevent unauthorized access by children. To avoid accidents, ensure that children cannot use this spa unless they are supervised at all times.

7. **DANGER**-Risk of Injury. The suction fittings in this spa are sized to match the specific water flow created by the pump. Should the need arise to replace the suction fittings or the pump, be sure that the flow rates are compatible. Never operate spa if the suction fittings are broken or missing. Never replace a suction fitting with one rated less than the flow rate marked on the original suction fitting.

8. **DANGER**-Risk of Electric Shock. Install at least 5 feet (1.5m) from all metal surfaces. As an alternative, a spa may be installed within 5 feet of metal surfaces if each metal surface is permanently connected by a minimum No. 8 AWG solid copper conductor to the wire connector on the terminal box that is provided for this purpose.

9. **DANGER**-Risk of Electric Shock. Do not permit any electric appliances, such as a light, telephone, radio or television within 5 feet (1.5m) of a spa.

10. **WARNING**-To Reduce the Risk of Injury:

A. The water in a spa should never exceed 40°C (104°F). Water temperature between 38°C (100°F) and 40°C (104°F) are considered safe for a healthy adult. Lower water tempera-

tures are recommended for young children and when spa use exceeds 10 minutes.

B. Since excessive water temperature has a high potential for causing fetal damage during the early months of pregnancy, pregnant or possibly pregnant women should limit spa water temperature to 38°C (100°F).

C. Before entering a spa, the user should measure the water temperature with an accurate thermometer since the tolerance of water temperature regulating devices varies.

D. The use of alcohol, drugs, or medication before or during spa use may lead to unconsciousness with the possibility of drowning.

E. Persons suffering from obesity or with a medical history of heart disease, low or high blood pressure, circulatory system problems, or diabetes should consult a physician before using a spa.

F. Persons using medication should consult with a physician before using a spa since some medications may induce drowsiness while other medications may affect heart rate, blood pressure, and circulation.

G. Do not allow you spa temperature to go above 40°C (104°F). Immersion in water above this point and prolonged immersion in water even at lower temperatures can cause hyperthermia.

HYPERTHERMIA

The cause, symptoms, and effects of hyperthermia may be described as follows: Hyperthermia occurs when the internal temperature of the body reaches a level several degrees above the normal body temperature of 98.6°F. The symptoms of hyperthermia include an increase in the internal temperature of the body, dizziness, lethargy, drowsiness, and fainting.

The effects of Hyperthermia include: (1) failure to perceive heat, (2) failure to recognize the need to exit spa or hot tub, (3) unawareness of impending hazard, (4) fetal damage in pregnant women, (5) physical inability to exit the spa or hot tub, and (6) unconsciousness resulting in the danger of drowning.

WARNING

The use of Alcohol, Drugs or Medication can greatly increase the risk of fatal Hyperthermia.

11. **SAVE THESE INSTRUCTIONS.**

WARNING

DO NOT EXCEED

104°F

**Check Water Temperature
Before Entering Spa**

A WORD ABOUT SPA FUN AND SAFETY

Your MORGAN spa provides year round enjoyment. For fun and safety, be sure you and your family members review this safety manual completely. Keep it on hand for future reference or pass it along to new owners. MORGAN recommends that you follow these safety precautions:

- Do not use the spa when pregnant, if you suffer from heart disease or high/low blood pressure unless you have obtained the approval of a medical doctor.
- If you are taking medication you should consult a medical doctor before using the spa.
- Do not use the spa when under the influence of alcohol or other drugs.

The calming effect of your spa in combination with the effects of alcohol and/or drugs are a dangerous combination which can induce unconsciousness that can lead to drowning in the spa water. It is critical that you understand the serious danger created by this combination, and do not use the spa under the influence of alcohol and/or drugs.

- Persons with long hair should wear a bathing cap when using the spa and small children with long hair and/or loose clothing should never be allowed to use the spa. Hair or clothing could be sucked into skimmers, suction fittings or drains causing serious injury or death.
- Using the spa alone is not recommended.
- Always check the water temperature before using the spa. Make sure the water temperature is never higher than 104°F (40°C).

Higher temperatures could result in serious bodily injury or death.

- Do not expose acrylic shell to direct sunlight for a long period of time. Replace your spa cover immediately after use.
- Be careful of wet and slippery surface. Use caution when entering and exiting the spa.
- Do not allow anyone to stand on the spa cover. It is not designed to support weight.
- Do not operate the pumps in high speed or jet operation with the cover in place. Extensive operation can cause heat build-up and damage your spa.

You don't have to take fun out of spa ownership. Your knowledge of safety precautions and good sense minimizes risks. One individual must assume responsibility for supervising the spa. This person should be thoroughly familiar with the contents of this manual and be responsible for enforcing "house rules" for your spa.

SPA LOCATION

MORGANS DOES NOT ASSUME ANY RESPONSIBILITY OF DAMAGE CAUSED BY WATER LEAKAGE OR WEIGHT OF THE SPA. SELECTING THE PROPER LOCATION FOR YOUR SPA IS VERY IMPORTANT.

IF NOT INSTALLED ON CONCRETE SLABS, MAKE SURE GROUND CONDITION WILL SUPPORT BLOCKING POINTS. IF SETTLING DOES OCCUR THE SPA WILL NEED TO BE RELEVELLED. FAILURE TO MAINTAIN A LEVEL SPA COULD DAMAGE YOUR SPA.

(Note: This is a typical blocking diagram.)

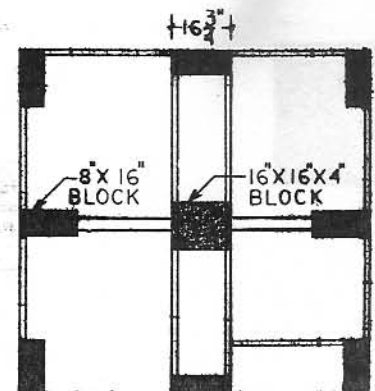

If your spa is to be located **OUTDOORS** consider the following:

- Local codes pertaining to fencing.
- Local electrical codes.
- View from house.
- Wind direction and sun exposure.
- Location relative to trees (falling leaves and shade).
- Dressing and bathroom locations.
- Storage area for maintenance equipment and chemicals.
- Landscaping and night time lighting.
- Sprinkler systems already installed in yard.
- Location to facilitate adult supervision.
- A level, hard surface capable of withstanding weight in excess of 4,000 lbs. (Larger spa models when filled with water.)
- Rain run-off from the roof.

If your spa is to be located **INDOORS** consider the following:

- Indoor spas develop high humidity. Removing this humidity can be accomplished by cross ventilation fans, oversized dehumidifiers, or both.
- Chemicals will evaporate off the water surface. This may cause corrosion to certain metals found in home hardware and appliances.
- Floor drains should be provided to carry off water splashed from the spa.
- Walls, ceilings, woodwork, etc. should be made from materials capable of withstanding high humidity.
- Be sure the supporting structure is capable of withstanding the weight of the spa which is in excess of 4,000 lbs. (Larger spa models when filled with water.)
- Be sure surface on which spa is to be put is smooth and level.

SPA ACCESSORIES

These accessory items are available through your **MORGAN** representative:

Complete line of chemicals
Ozonators
Spa fragrances
Replacement filter cartridges
Pillows
Thermometers

Complete line of redwood products to include:
spazebos * mood rooms
cabanas * towel bars

W A R N I N G

FOR YOUR SAFETY RISK OF ELECTRICAL SHOCK

MORGAN REQUIRES THAT YOUR SPA BE WIRED BY A LICENSED ELECTRICIAN.

GFCI PROTECTION IS PROVIDED ON ALL 120 VOLT OPERATED SPAS BY MEANS OF A CORD END GFCI. PLUG THIS CORD END GFCI DIRECTLY INTO A 20 AMP DEDICATED CIRCUIT.

NO GFCI PROTECTION IS PROVIDED FOR 240 VOLT OPERATED SPAS. YOUR ELECTRICIAN MUST PROVIDE GFCI PROTECTION.

YOUR SPA MUST BE GROUNDED IN ACCORDANCE WITH THE NATIONAL ELECTRIC CODE.

(Revised: 4/15/98)

FIELD WIRING DIAGRAM
120/240V Morgan Convertible Digital Control System

DANGER
RISK OF ELECTRIC SHOCK

120 Volt Wiring Diagram

THIS UNIT IS PRE-WIRED WITH A 120V, 20AMP GFCI POWER CORD. THIS MUST BE PLUGGED INTO A 120V, 20AMP DEDICATED RECEPTACLE. NO OTHER DEVICE MAY BE ON THIS CIRCUIT. PLUG INTO AN APPROVED GROUNDING TYPE RECEPTACLE ONLY.

DO NOT ATTEMPT TO ALTER THE PLUG OR USE CONVERTERS TO FIT OTHER RECEPTACLE CONFIGURATIONS.

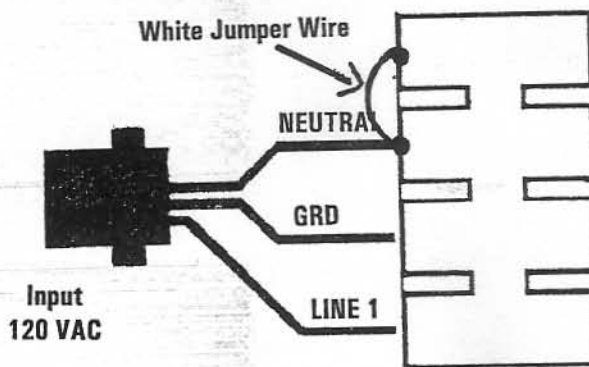

120 Volt Wiring Diagram

For 120/240V Convertible Digital Pack

Volts 120; Amps 16, 2 Wire Plus Ground
Conductor Ampacity 20 Amps Circuit Breaker 20 Amps
1 Phase, 60 Hz

240 Volt Wiring Diagram

CONVERSION TO 240V: CONVERSION TO 240V MUST BE DONE BY A LICENSED ELECTRICIAN ONLY. TO WIRE THE SYSTEM FOR 240V OPERATION: SUPPLY INPUT POWER AS INDICATED IN THE FIGURE.

THE 120V POWER CORD THAT CAME WITH THE UNIT MUST BE REMOVED AND DISCARDED WHEN THE UNIT IS CONVERTED TO 240V.

THE UNIT WILL AUTOMATICALLY BE CONVERTED TO 240V WHEN WIRED AS SHOWN.

REMOVE GFCI POWER CORD AND WHITE JUMPER WIRE ON TERMINAL BLOCK FROM L-2 AND NEUTRAL.

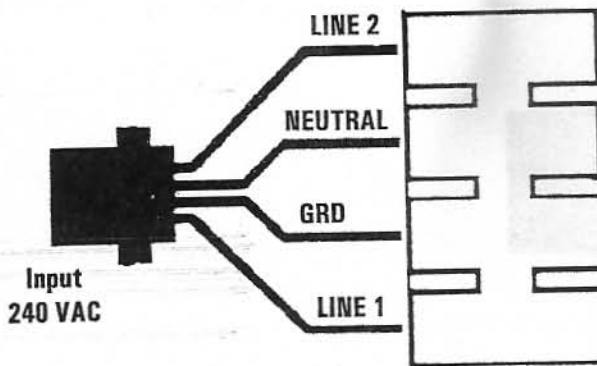

240 Volt Wiring Diagram

Volts 240; Amps 39; 3 Wire Plus Ground
Conductor Ampacity 49 Amps
Ground Fault Circuit Interrupter, 50 Amps
1 Phase, 60Hz

FIELD WIRING DIAGRAM
(For Morgan Deluxe Digital Single Pump Control System)
(For Morgan Dual Pump Control System)
(For Morgan Digital Single Pump Control System)

240V Digital Control System
240 Volt Wiring

DANGER
RISK OF ELECTRIC SHOCK

ALL WIRING MUST BE DONE BY A LICENSED ELECTRICIAN ONLY

240V Digital Single Pump
Volts 240, Amps 35, 3 Wire Plus Ground
Digital Control System
Conductor Ampacity 44 Amps
Ground Fault Circuit Interrupter
50 Amps
1 Phase, 60 Hz

240V Dual Digital Pump
Volts 240, Amps 40, 3 Wire Plus Ground
Digital Control System
Conductor Ampacity 50 Amps
Ground Fault Circuit Interrupter
50 Amps
1 Phase, 60 Hz

240 VOLT WIRING DIAGRAM

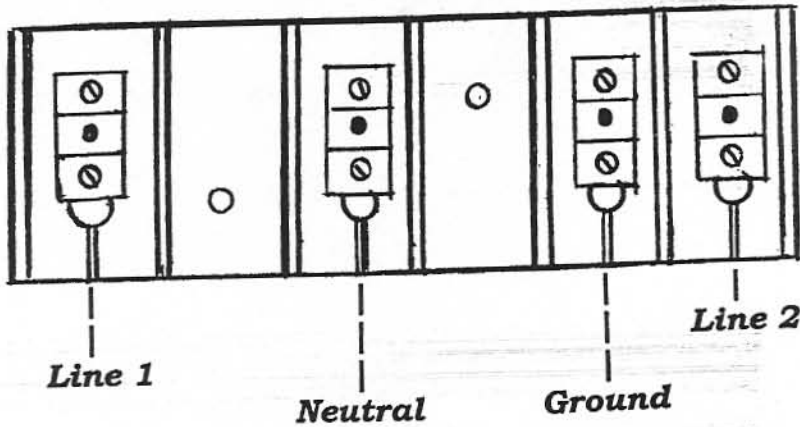

INITIAL FILL & STARTUP

- **Turn off all electrical power to the spa.**
- The equipment pack must never be operated without water in the spa, as serious damage to the heater and/or pump could result.
- Fill your spa with normal tap water. Do not use water from any type of water softener.
- Fill the spa with water to the recommended level, which is approximately 5 inches from the top.
- It is important to run the pump for several minutes to remove all the air from the system.
- At this time, add MORGAN Metal Protector and Stain Preventor. ***All chemicals should be added with the spa in blower mode only.*** Add MORGAN Shock-Out to activate your Morgan Nature 2 spa purifier which is inside the cartridge filter. Follow the recipe given in the Spa Purification section under Section 6, Chemicals.
- At this time you will need to test your water with the Test Strips, which you will find in your chemical start-up kit. Check the water's total alkalinity and pH and adjust to proper level. Refer to Section 7 in this manual for instructions or you may refer to the Water Balance of Spa Maintenance Guide that is provided in your chemical start-up kit.
- Allow the spa to remain ON in low speed mode or filtration cycle for 24 hours, then clean the filter thoroughly. You will need to refer to the "filtration cycle section" found in Section 5, Recommended Maintenance Schedule.

IMPORTANT NOTE:
Read and follow all instructions on the chemical labels.

SECTION 2 Morgan Digital Control Systems

Morgan Digital Single Pump 240V Control System

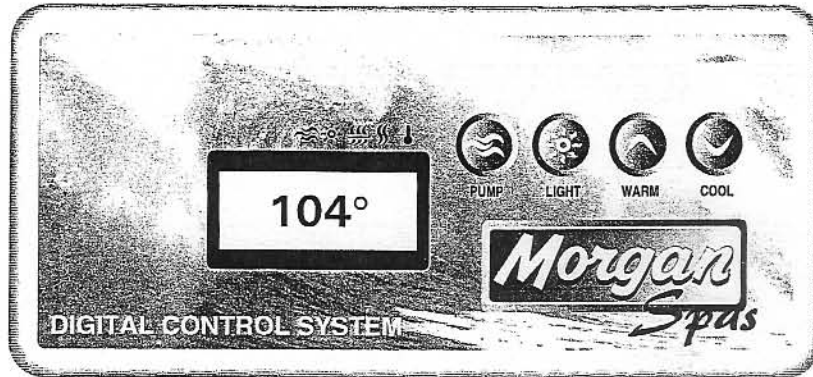

Morgan Convertible Digital Control System

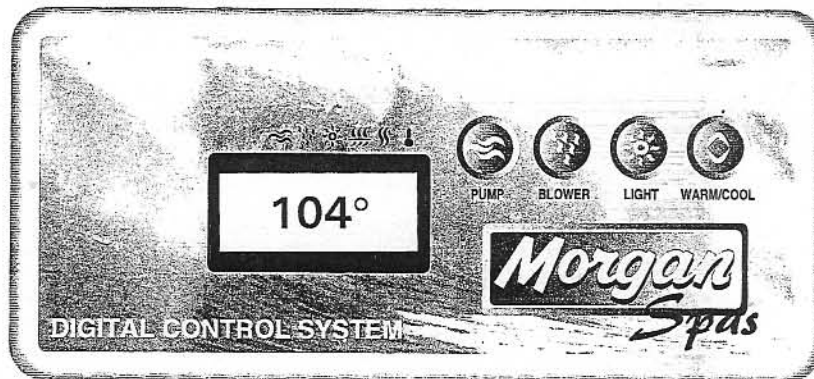

CONTROLS

Start the pump:

Press on the Pump key to turn pump on. A second press will change pump speed. A third press will turn pump off. A built-in timer will shut pump off 30 minutes after it has been started unless you have done so manually. The Pump On triangular icon will appear on the display when the pump is running.

Start the Blower (blower may not be featured on all digital control systems):

Press on the Blower key to turn blower on. A second press will turn blower off. A built-in timer will shut the blower off 30 minutes after it has been started unless you have done so manually. The Blower On icon will appear on the display when the blower is running.

Turn on the Light:

Press the Light key to turn the light on. A second press will turn the light off. The light will

automatically shut itself off after 2 hours. The Light On icon will appear on the display when the light is on.

Change the Water Temperature (some units will have either 1 key to represent Up and Down or may have 2 keys, one each for the Up and Down key):

The Up and Down arrow key(s) is used to set the temperature of the water.

Keeping the pressure on the key will increase (or decrease) the current temperature setting. The new and desired temperature setting will remain for 5 seconds on the LED display as a confirmation of its new value.

The Set Point triangular icon appearing on the display tells you that the temperature shown is the desired, and not the actual, temperature of the water. The temperature can be adjusted in 1° increments from 59° to 104°F (or from 15° to 40°C).

Water heater automatic start: When the water temperature is 1°F lower than the set point, the heater will be turned on until the water temperature reaches the set point plus 1°F. The Heater On triangular icon will appear on the display when the heater is on.

Activate the Standby Mode:

To activate the Standby Mode, press the Pump key and hold for 5 seconds. The system will turn all outputs off for 30 minutes and the SBY message will appear on the display. Press any key to return to the normal mode.

PROGRAMMING

Program the Duration of the Filtration Cycles:

The system will automatically perform two filtering cycles per day, 12 hours apart. During a cycle, the pumps will be activated for a predetermined number of hours. To set the duration of the filtering cycle (the amount of time the pumps will be on), follow this procedure:

- Press the Light key and hold for 5 seconds. The display will show a value that represents the duration of the filter cycle in hours.
- Use the Up and Down arrows key(s) to change the number of hours. 0 = no filtration, 12 = continuous filtration.
- When the desired setting is displayed, press the light key again. The filter cycle will start. The Filter On triangular icon will appear on the display when a filtration cycle is on.

Note that after a power failure, the filter cycle duration will return to its default value (6 hours). In this case, the first filter cycle will start 12 hours after the power has been restored.

Note also that to prevent excessive water temperature caused by too long filtration cycles, the system will cancel a filter cycle if the water temperature raises more than 2°F above the set point. In this case, the filter cycle triangular icon will flash on the display.

PROBLEMS & CORRECTIVE ACTIONS

 The Heater On triangular icon flashed on the display when the pump is in high speed. Not a bug but a feature! The system is turning the heater OFF when the pump is in high speed to limit the amount of electrical current drawn.

 The pump starts by itself for 1 minute on several occasions and the filter cycle triangular icon is flashing on the display when that happens. Not a bug but a feature! The Smart Winter Mode of the spa pack protects the spa from the cold by turning on the pump for 1 minute several times a day to prevent the water from freezing in the plumbing.

HL The HL error message appears on the display. The system has shut down the heater because the water temperature at the heater has reached 118°F. DO NOT ENTER the water. Remove the spa cover and allow the water to cool down to 104°F, then press a key to reset the system. Call your service supplier or dealer if the problem persists.

FLO The FLO error message appears on the display. The system does not detect any water pressure when the pump is turned on. Check and open water valves. Check for water level. Clean filter. If the problem persists, call your service supplier or dealer.

FLC The FLC error message appears on the display. The system detects a problem with the pressure switch. Call your service supplier or dealer. If the display is flashing, a power failure may have occurred. Press any key to stop the flashing and reprogram your filter cycle.

Prr The Prr error message appears on the display. The system detects a problem with the temperature probe. Call your service supplier or dealer.

- oH** The system water temperature has exceeded 118°F (48°C), causing the heater to automatically shut OFF. When the water temperature has dropped below 104°F (40°C), press the TEMP touch button to reset the heater. If this error message continues to occur, discontinue use of the spa and contact your dealer to correct the problem.
- Fr** The system water temperature has dropped below the minimum set point of 40°F (4°C). An automatic freeze protection will activate the pump(s) and heater - protecting the system from freeze damage. The heater and pump(s) will operate until the water has reached 43°F (6°C).
- Flo** The flow switch is not measuring adequate water flow to permit heater operation. Check the spa for closed valves, low water level, or a dirty filter cartridge. If this error continues, discontinue use and contact your dealer to correct the problem.
- ErO** The water temperature regulating sensor has malfunctioned or is not properly connected. If either ErO or Er1 error message is displayed, discontinue use and contact your dealer to correct the problem.
- Er2** The water temperature high-limit sensor has malfunctioned or is not properly connected. If either Er2 or Er3 error message is displayed, discontinue use and contact your dealer to correct the problem.
- Er3**
- Er4** The heater flow switch has malfunctioned. If this error message is displayed, discontinue use and contact your dealer to correct the problem.

Normal Operating Messages

- Fc** Whenever a timed filtration cycle is in operation, the Fc message and the current water temperature are alternately displayed on the LED.
- diS** Whenever in a system disable mode (for maintenance), diS and the remaining system disable time are alternately displayed on the LED.

SECTION 3

Morgan II Deluxe Digital Single Pump Control System

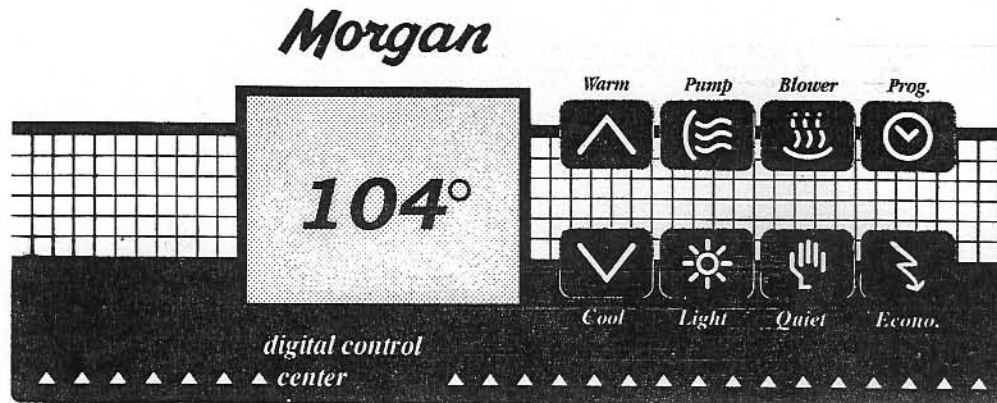

Pump switch

This key is used to control the pump #1 output. Successive presses of this key will turn on the pump in the following sequence:

- Pump #1 low only
- Pump #1 high only
- Pump off, unless spa is in an active filter cycle

Morgan II Deluxe Digital Dual Pump Control System

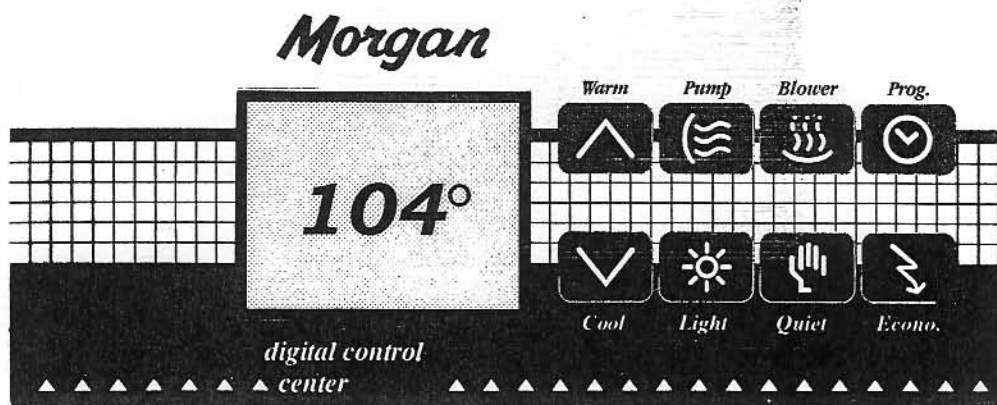

Pump switch

This key is used to control the pump #1 and pump #2 outputs. Successive presses of this key will turn on the pumps in the following sequence:

- Pump #1 low only
- Pump #1 high only
- Pump #1 high and Pump #2 high
- Pump #2 high only
- Both pumps off, unless spa is in an active filter cycle

A built-in 30 minute timer will shut the pump(s) off, unless the user does so manually. When a pump is active (#1, #2, or both), the corresponding icon on the display will be on too. Note that in the case of Pump #1 Low, the Pump #1 icon will blink. Note that if there is a call for Heat, or if there is an active Filter cycle Pump #1 cannot be turned off, it will remain on in Low speed.

Up and Down Keypad

These keys are used to set the temperature of the water and program some system functions. As soon as the user presses one of these keys, the display will show the current set point and will keep showing it for five (5) seconds after releasing the key. Pressing the keys will either increase or decrease the current set point. The set point logo on the display tells the user if the display shows the current set point or the actual temperature of the water.

The water temperature can be adjusted in one (1) degree increments from 59° to 104°F (or from 15° to 40°C).

When the water temperature is 1°F (0.5°C) lower than the set point, the heater will come on until the water temperature reaches the set point plus 1°F (0.5°C). The heater logo on the display will blink when the system calls for heat and will come on when the heater is actually turned on.

Quiet/Standby Keypad

This key is used to manually shut off all outputs (Pump #1, pump #2, and Blower). However, if there is a call for Heat, or an active Filter cycle, Pump #1 will remain on in Low speed.

If the key is pressed and held for 5 seconds, the spa will enter the standby mode. In this mode, all outputs are off (including Pump #1, even if a call for Heat is present, or a Filter cycle is active) and the display will show "Stby". This mode allows the user to change the spa's filter. The user then presses any key to exit the standby mode and the spa resumes normal operation. Should the user forget to exit the standby mode, the spa will automatically resume normal operation after 30 minutes.

Blower Keypad

When the Blower keypad is pressed shortly, it will turn on the blower in high speed. When

pressed shortly a second time, it will turn off the blower. If the blower keypad is held (when the blower is on), the blower's speed will continuously vary from High to Low, and then back to High. A built-in timer will shut the blower off after 30 minutes if it hasn't been shut off automatically. When the blower is on, the blower logo on the LCD display will also turn on.

Light Keypad

Successive presses on this key will turn the Light on at High, Low, and then Off. The light will automatically shut off after 2 hours. When the light is on, the light logo on the display will also be on (it will blink in low intensity).

Panel Lock

It is possible to lock out the programming functions of the keypad. This feature is helpful when young children could have access to the keypad and disturb wanted settings. To lock the keypad, see the *Program Keypad* description. When the panel is locked, it is impossible to re-program the system, change the Economy mode, or modify the set point temperature. If an attempt is made to do these changes, the display will show "Loc" for about 2 seconds. To unlock the keypad, see *To Unlock Keypad* description.

Program Keypad

This key is used to program five (5) functions. These functions are: Time of day, filter cycle start time, filter cycle duration, display temperature units, and finally, keypad lock mode. The following explains the necessary steps to program the unit:

- **Setting the Time:** Hold the *Program* key until the program display icon lights up (about 2 seconds). The display will then show the current time of day. Using the *Up* and *Down* keys, adjust the current time.
- **Setting Filter Cycle Start Time:** Press the *Program* key a second time. The display will show 'Fsxx', where xx is the filter cycle start hour. This may be adjusted (using the *Up/Down* keys) to anywhere from 1 to 11. The filter cycle starts twice (2) a day at the selected hour. For example, if xx is 8, the filter cycle will start at 8:00 AM (morning cycle) and at 8:00 PM (evening cycle).

- **Setting Filter Cycle Duration:** Press the *Program* key a third time. The display will show 'Fdxx', where xx is the filter cycle duration, in hours. This may be adjusted (using the *Up/Down* keys) to anywhere from 0 to 12. If xx is 0, the filter cycle is turned off (it will never start). If xx is 12, the filter cycle is always on. Note that even if the filter cycle is always on, the pump #2 and blower outputs (if installed) will be purged at the filter start hour (i.e. twice a day).
- **Selecting F° or C° :** Press the *Program* key again. The display will show 'Tu x', where x is either Fahrenheit or Celsius. This is the temperature units that will be used to display the spa temperature and the set point. Use the *Up/Down* keys to select the desired units.
- **To Lock Panel:** Press the *Program* key again. This brings up the last function that may be programmed, the keypad lock mode. The display will show Loc 'O'. To lock the keypad use the *Up* arrow to get Loc '1' on the display. The lock icon on the display will turn on. Note: The lock function only disables the keys used to change parameters, the four basic keys (pump1, pump2, light and blower) will still function.
- A final press of the *Program* key stores the programming into non-volatile memory and exits to the normal time/temperature display.

At any time during programming, if the user does not touch the keypad for more than 10 seconds, the unit will exit the programming mode and go back to normal display. Any changes done so far are saved. In programming mode, the only keys allowed are the *Program, Up and Down* keys.

To Unlock Keypad

To unlock the keypad, the following steps must be FOLLOWED IN THEIR CORRECT ORDER:

- Press the *Program* keypad. The display will show 'Loc', but this will remain for approximately 10 seconds to give the user time to do the rest of the unlock sequence.
- Press the *Up* keypad.
- Press the *Pump #1* keypad.

- Press the *Light* keypad. The keypad is then unlocked and all the spa functions are accessible to the user.

Economy Keypad

This keypad is used to set the spa Economy mode. There are three (3) available operating modes:

- Normal mode (no economy). This mode is the default mode of operation. The heater will always regulate the spa temperature to the desired set point.
- Economy mode #1. Economy always on. In this mode, the heater will regulate the spa temperature to 20°F (11°C) BELOW the desired set point. This is an energy saving mode. In this mode, the economy logo is lit on the display.
- Economy mode #2. This mode is a variant of mode #1. The difference is the period in which the mode is active. Between 4 PM and 9 PM, the heater regulates the spa temperature normally (desired set point). Outside of this 5-hour time period, the heater will regulate as if in economy mode #1 (BELOW desired set point).

To select the wanted economy mode, press the *Economy* keypad. The display will then show the current mode that is set ('noEC', 'EC 1', or 'EC 2'). Keep pressing the economy keypad until the desired mode is displayed. After approximately five (5) seconds, the new setting is saved and the spa returns to normal time/temperature display.

Other Features

Alternating Temperature/Time Display

Every five (5) seconds, the display normally alternates between the current time and the actual spa temperature.

Side-Panel

This keypad has four (4) keys which have exactly the same functionality as the pump, blower, light and quiet/standby keys on the main keypad. It gives users the possibility of

operating the spa from another location within the spa.

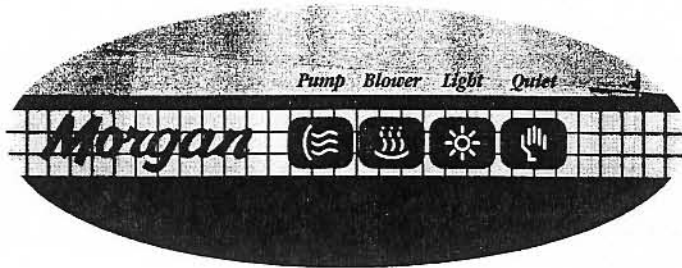

Ozone Output

This output is turned on during the filter cycle. However, if the spa is being used (pump #1, pump #2, or blower outputs are manually turned on), the ozone output will stay off until the spa is not in use anymore.

High Limit

The high limit circuit will shut the heater off if the temperature of the water at the high-limit sensor reaches 119°F. Should this occur, the display will show HL but all of the accessories will still function. The heater will remain off until someone presses a key on either keypad to reset the circuit.

Pressure Switch

The controller is always checking the current state of the pressure switch. When pump #1 is not running, the pressure switch must be open, if not, an 'FL C' error occurs.

When the pump is on, the pressure switch is given five (5) seconds to close. If, after this delay, the switch is still open, an 'FL O' error occurs. During this five (5) second delay, the heater can't be turned on. Also, the heater may be turned on only if the flow switch is closed while the pump is running.

If an FLO/FLC error occurs, only the heater is turned off. The other spa accessories will continue to run. If the system detects that the error condition no longer exists, it will clear the error itself, thus removing the error message from the display and re-allowing the heater to function normally.

Smart Winter Mode

This system prevents the water from freezing in the pump plumbing. An onboard sensor continuously checks the ambient air temperature in the pack. If at any time the temperature goes below 60°F the system activates the winter mode for the next 24 hours. In this mode, if the pumps haven't been turned on during the last two (2) hours, the system will start them (see note) for one (1) minute to circulate warmer water in the plumbing. When the pumps are running because of this protective feature, the filter cycle icon on the display will blink.

Note: The pumps will come on according to the following sequence:

- Pump #1 low for 2 seconds
- Pump #1 high for the rest of the cycle.
- Pump #2 high, 2 seconds, AFTER pump #1 has gone to high speed.

Power-Up Detection

After a power-up, the display will blink until somebody presses a key. This feature is to let the user know that a power failure has occurred and that the onboard clock may need re-programming (see Program switch description). Normally, the onboard clock can keep the correct time for at least 48 hours during a power failure. Note that a power failure does NOT affect any other programming, only the clock itself may be affected.

Temperature Sensor Failure

If the value returned by the temperature sensor does not seem to be in the normal range, the display will show the message "Pr" and the heater will not be allowed to turn on. This feature is disabled during the first hour after a power-up. This is to allow a spa, freshly filled with very cold water (ie. less than 34°F), to function normally (heat up).

Trouble Shooting Guide

SYMPTOM	POSSIBLE CAUSE	CORRECTIVE ACTION
Equipment pack does not operate	Fuse	Replace fuse on front panel
	Tripped GFCI breaker, main panel.	Reset, if breaker will not reset, call for service.
	Cord end GFCI has tripped.	Push "reset." If the GFCI will not "reset," the possibility of shock exists. Call Morgan representative for repairs. Applies to 120/240V convertible models only.
	Check display panel for message for trouble shooting.	Refer to Trouble Shooting Guide under Digital Controls.
Low flow of water, reduced jet action.	Clogged filter.	Clean filter.
	Plugged or restricted discharge line or suction line.	If obstruction is not visible, contact your Morgan representative.
	Water level too low.	Add water.
Pump leaks at shaft.	Partially closed inlet or outlet slide valve.	Make sure the handles of the slide valve are pulled out all the way.
	Bad seal.	Contact your Morgan representative.
Equipment pack works, but heater does not work.	Equipment pack is not receiving 240V but wired for 240V.	Have checked by a qualified electrician.
	Temperature set too low.	Turn temperature higher.
	Hi-limit switch tripped.	Check display panel. Refer to Trouble Shooting Guide under Digital Controls.
	Spa in wrong mode (economy).	Put spa in correct mode.
Does not heat to proper temperature.	Spa cover left off.	Using spa cover when the spa is not in use will shorten the heating time.
	Did not allow adequate time for initial heating.	Allow adequate time for initial heating. Minimum 24 hours for 120V and 8 hours for 240V.
	Temperature too low.	Turn temperature higher.
Pump runs, but won't prime. No water coming from jets.	Air in filter system.	Open bleeder valve at top of filter canister until steady stream of water begins.
	Inlet or outlet valve closed.	Open valve.
	Impeller clogged.	Contact your Morgan representative.
Pump motor hums, but does not start.	Water level too low.	Add water.
	Binding of motor shaft.	Contact your Morgan representative.
Noisy pump.	Improperly wired.	Contact qualified electrician.
	Motor loose on mounting.	Tighten.
	Foreign material in pump.	Disassemble pump and clean. Contact your Morgan representative.
	Impeller damaged.	Contact your Morgan representative.
	Worn bearing.	Contact your Morgan representative.

SECTION 4 Air Controls & Jets

Note: Jet and valve styles shown will not be found in all models of spas.

Air Controls

The air controls are found on the control panel and, on some models, along the top edge of your spa. These control the amount of air mixed with water. The more air mixed in, the greater the jet action.



The different location of air controls enables you to vary the jet action in different areas of the spa at the same time. **Note:** It is a good habit to turn air controls off after each use of the spa.

There are two different methods to supply air to the jets to increase the jet action:

- Turn on jet pump and turn controls counter-clockwise (increase). The jets will create a natural air draw and increase the jet action.

- Turbo charge: Turn on jet pump and blower, turn controls counter-

clockwise to Turbo Jet. This will give you maximum jet action.

CAUTION: IF SPA IS LEFT IN BLOWER MODE ONLY AND THE TURBO CHARGER IS LEFT ON, YOU MAY EXPERIENCE SOME WATER SPLASHING OUT OF THE SPA.

On spa models with an infinite speed blower, by depressing the blower button you can control the turbo action to the jet.

Total Turbo Valve



This valve allows you to direct air to enjoy a powerful massage, or a bubbling sensation, or both.

Turbo Jets - Air is diverted to the jets for a more powerful massage.

Turbo Air - Air is diverted to the air-injector jets for a bubbling sensation.

Total Turbo - Air is diverted to allow for a more powerful massage and a bubbling sensation.

Power Collar Valve



This valve increases or decreases the water velocity to the mini-luxury jets in the power collar area.

Waterflow Control Valve

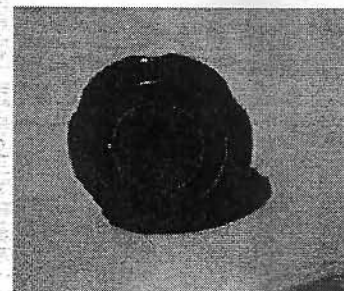

This valve is used to increase or decrease the water pressure flow to the neck jets or the mini luxury jets.

The neck jets are located above water level at the head of the lounge or in a seat location depending on your model of spa.

The mini luxury jets are located in a collar which your shoulders fit underneath. By adjusting the flow control valve which is located in arms reach of the seated location you are sure to get the ultimate massage.

Cyclone Jet

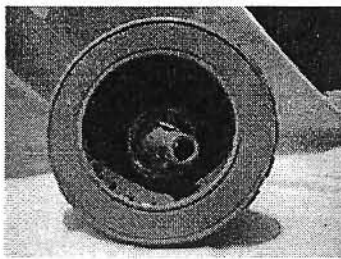

It gives a truly remarkable and powerful massage by boasting a 360° circular motion and can be adjusted for pressure and direction.

Ultramassage Luxury Jet

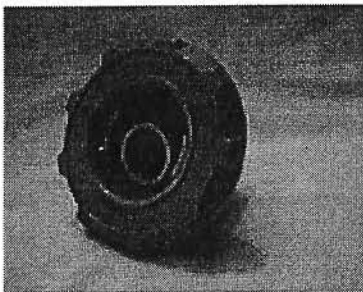

The luxury jet is adjustable. To adjust the luxury jets, turn the jet face clockwise to reduce the water flow, or counter-clockwise to increase the water flow. By moving the nozzle in the center, you can adjust the direction of the jets water flow.

To remove the luxury nozzle turn the two tabs on either side of the nozzle counter-clockwise a quarter of a turn then grab the inner nozzle and pull out.

To install a luxury nozzle insert the nozzle all the way in and turn clockwise until it stops, which is the locked in position.

The Ultramassage Luxury Jet is interchangeable with the Flutter Blaster Jet.

Flutter Blaster Jet

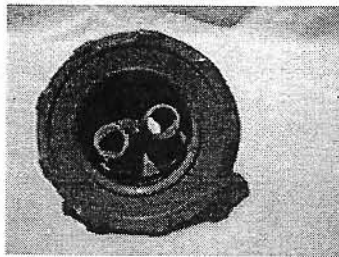

Flutter spinning motion gives a unique and pleasurable massaging sensation. Jets can be easily adjusted for water flow necessary for effective hydrotherapy by turning the jet face clockwise to reduce the water flow, or counter-clockwise to increase the water flow.

To remove nozzle grab nozzle with both index finger and thumb. While pulling out give nozzle a slight upward or downward motion. To install nozzle push nozzle into jet body until it locks in place.

The Flutter Blaster Jet is interchangeable with the Ultramassage Luxury Jet.

Mini Luxury Jet

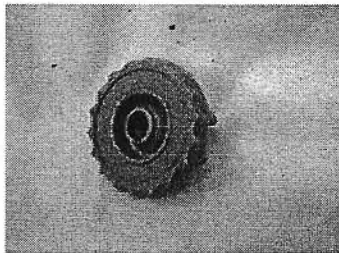

Gives massaging action similar to the full size Luxury jet but with a smaller plume of water. Range of adjustability helps you customize your hydro-therapy by turning the jet face clockwise to reduce the water flow, or counter-clockwise to increase the water flow.

Mini Flutter Blaster Jet

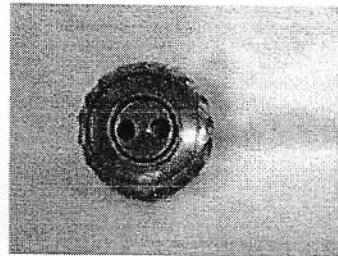

Unique flutter action that provides tingling sensations similar to the large Flutter Blaster. Great adjustability helps you to select the hydrotherapy that fits your needs.

Non-Adjustable Directional Euro Jet & Ozone Jet

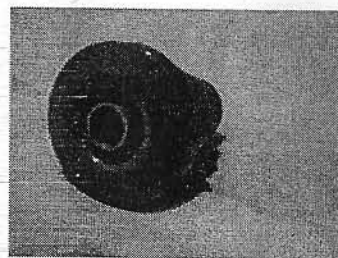

This jet has a unique soft-massaging action. By moving the nozzle in the center you can adjust the direction of the jet water flow. This jet also serves as the entry point for your ozonator output.

Non-Adjustable Pulsator Euro Jet

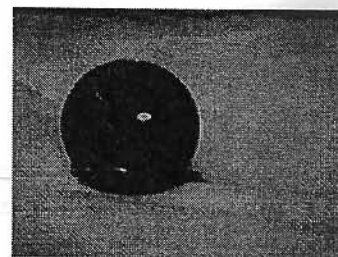

This jet has a unique spinning motion with a soft-massaging action.

Air Injector Jet

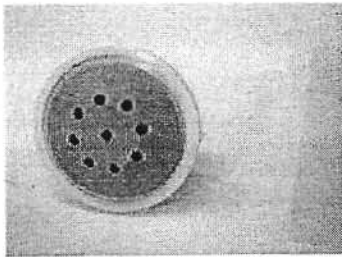

This jet is powered by air and gives a unique bubbling sensation action.

Air Action Jet

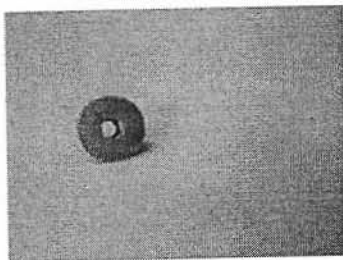

This jet is powered by air and gives a bubbling action.

Neck Jet

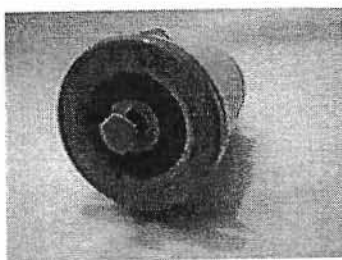

The ultimate neck massage. The jet is located out of the water. Flow goes directly onto the body for greater hydrotherapy. Nozzle is multi-directional and is easily adjusted. Flow can be adjusted by turning knob on valve located to the left or right of seated location. Pushing the jet nozzle in turns the jet off. Pulling it back out returns the jet to full operation.

Swirlpool Jet

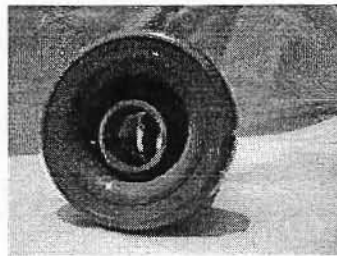

This jet creates a whirlpool within the spa. Point the nozzle in the direction you want the whirlpool and open the jet by turning the jet face clockwise. To reduce the whirlpool, or close the jet entirely, turn the jet face counter-clockwise.

When turned on the swirlpool jet takes water flow from a series of other jets to supply it with a powerful water flow. When the swirlpool jet is turned off, the water then returns to the other jets.

Diverter Valve

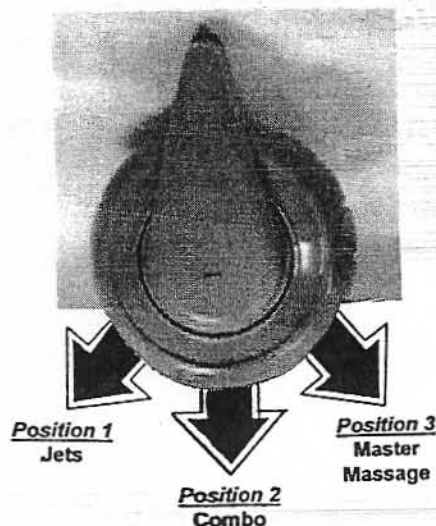

The diverter valve allows you to direct the full flow of water to a specific series of jets to maximize intensity; or you can split the flow equally between two different series

of jets for normal massage action.

Position 1: The full flow is directed to the therapy jets.

Position 2: The flow is split between the master massage jet and the therapy jets.

Position 3: The full flow is directed to the master massage jet.

Master Massage Jet

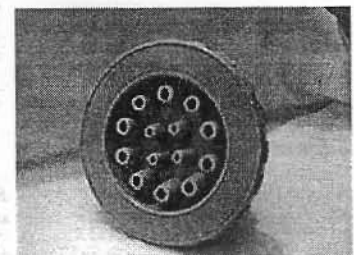

An 8" jet with 14 orifices that are controlled by a diverter valve to get a full flow and create a whirlpool action or to divert some water flow away from the jet to customize your own therapeutic needs.

SECTION 5 Maintaining Your Portable Spa

Your MORGAN spa, just like any other appliance, must be regularly maintained. MORGAN recommends that the following maintenance and operation procedures be followed:

- The filtration system of your spa should be run at least 6 hours a day to keep the spa clean. These 6 hours required should be met at two different intervals of a 24 hour day with one interval being right after normal use of the spa.
- The air blower should be used only when people are in the spa or adding chemicals. This will minimize heat loss and prevent unnecessary dissipation of chemicals.
- Effective usage of your chemicals is determined by the pH of the water in your spa. Refer to your manual on testing procedure and how to use your test strips.
- Follow the recipe for use of MORGAN Shock-Out along with your Nature 2 Purifier.

WARNING:
**CHECK WATER TEMPERATURE
BEFORE ENTERING SPA.
WATER TEMPERATURE
MUST NOT
EXCEED 104°F.**

Recommended Maintenance Schedule For Your Spa

The following directions are important for your reference in keeping your spa bright, clean and sanitary. Follow the MORGAN Spa Maintenance Guide included with your spa. The following schedule is recommended to maintain your spa:

Note: Before each use add 1 tablespoon of MORGAN Shock Out per every 250 gallons.

Mondays:

- Test your water for pH level.
- Adjust pH and total alkalinity. Refer to chart in the MORGAN Spa Maintenance Guide.
- Add 1 ounce of Spa Clear & Bright to your water. This will aid in the removal of both organic and inorganic suspended particles in the water.

Wednesdays:

- Test your water for pH level.
- Adjust pH and total alkalinity, if necessary.
- Add MORGAN Metal Protector to your spa to aid in the prevention and elimination of calcium precipitation and scaling; iron, copper or manganese staining. This is especially recommended in areas with water high in calcium, total alkalinity and pH.

Fridays:

- Repeat Monday's program.
- Super oxidize the spa with MORGAN Shock Out.

MAINTENANCE SCHEDULE

Usage	Clean Filter	Replace Nature2 Purifier
1-3 uses weekly	Every 2 months	Every 4 months
4+ uses weekly	Every month	Every 4 months

This schedule may vary depending on the use and care of your spa. Anytime the jet pressure decreases, immediately check and clean the filter. The above schedule represents an average spa with average usage. Under heavy usage you should check and make chemical additions to your spa more often than suggested.

We strongly recommend that you refer to the "MORGAN SPA MAINTENANCE GUIDE" included in your spa start-up kit for a better understanding of the spa chemicals and their use.

Cleaning and Changing Filter Cartridge

The top-load filter is located under the small decorative cover on the top lip of the spa. **Caution:** Do not try to remove the lock-ring or filter cap "manifold" before placing your spa in the stand-by mode. Open the air relief valve.

Remove the lock-ring then remove the filter cap "manifold" by lifting or pulling on the handle. The cartridge filter element can now be removed and cleaned by squirting in between the pleats with a garden hose. Rotate the cartridge housing from top down. After hosing the cartridge filter, allow the cartridge to dry and carefully brush the pleated surface area to remove the particles. Once cleaned, or new filter cartridge has been replaced and the manifold reinstalled, make sure the lock-ring has been installed properly and locked in place. **Caution:** Do not try to operate the spa without the filter or without replacing the lock-ring on the manifold. Trying to operate the spa with the manifold in place but without the lock-ring properly in place and locked may cause injury. **Note:** You should lubricate the o-ring with silicone based lubricant (absolutely non-petroleum based), this will make installing much easier.

Algae, suntan oil and body oils form a coating on the cartridge pleats which may not be thoroughly removed by hosing. To remove such materials, spray the cartridge with MORGAN Rapid Filter Rinse which may be purchased at any MORGAN spa sales location. Follow the directions on the label for use. After cleaning, hose the filter thoroughly before re-installing. Depending on use and care, the filter cartridge should be cleaned monthly or more often with heavy use.

How To Drain and Clean Your Spa

- Turn off the main power supply.
- Remove plug from the drain/fill valve located in the toe kick of the cabinet, on the same side as the equipment pack. Attach the male end of a garden hose; route the hose to a safe discharge area, as chemically treated water may damage plants.

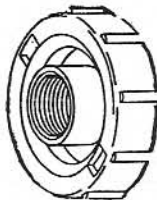

- Turn the face of the valve counter-clockwise to the open position. You will need to allow approximately 3 hours for the spa to drain depending on its size. Any remaining water can be removed with a small plastic container.

- After you have washed out your spa, clean with an approved acrylic cleaner. Several brands are now on the market. Dry it with a clean non-abrasive cloth.
- Apply a layer of Morgan Quik-Gloss to the acrylic surface, available at your MORGAN sales location. This will give a shiny, silky-smooth finish to your spa for added beauty and comfort.
- At this time you need to also clean or change the filter cartridge. Refer to section on "Cleaning and Changing Filter Cartridges."
- You may leave hose attached to drain/fill valve to refill the spa. After spa is filled, turn the valve counter-clockwise to the close position. Replace the plug in the valve; this will keep spa from draining if valve gets accidentally turned to the "On" position.
- Run in the high jet mode until you have good water circulation.
- Add chemicals and recommended amount of Metal Protector. Metal protector is very important in order to prevent calcium buildup. See section on "Initial Start-up."

Care and Upkeep

The Redwood Cabinet

MORGAN only uses the finest redwood for its cabinets. If exposed to the elements without a protective finish, the wood will turn to a natural gray finish. To preserve the original beauty of the redwood color it is recommended that you retreat your spa cabinet at least once every 6 months. Morgan wood sealers are available from the location you purchased your spa.

The cabinet, on most spa models, is designed with removable panels around the exterior of the spa. By removing the four (4) screws on the upper and lower portion of the panel, they can be removed for access to the equipment and other components of the spa.

Acrylic Finish

Your spa tub is constructed of cross-linked acrylic, some of the most chemical resistant material available. However, care should be exercised not to drop objects or rub sharp objects on the surface as the material can be scratched by doing so.

If scratches do occur, a polishing compound (the kind most used on automobile) can be used to remove them. Also, sanding with a 600-Grit wet/dry sandpaper lightly can remove these scratches. CAUTION should be exercised when sanding the surface. MORGAN Quik Gloss will brighten the acrylic finish.

To protect your spa finish, always keep your spa covered when not in use. Keeping the spa uncovered when not in use could cause severe damage to the acrylic by heat buildup from the sun. Such damage will not be covered by your warranty.

Spa Cover

Your MORGAN spa is furnished with an attractive insulated vinyl cover. Two hold-down straps are manufactured into the spa cover. These buckles offer protection to secure the spa cover to the spa cabinet in windy conditions BUT are not intended to "child proof" the spa. Morgans does offer a locking strap for this intended purpose.

The cover is constructed of marine grade vinyl. Washing with a mild soap solution regularly will maintain the luster. Treat the spa cover with Morgan Spa Care Treat at least once every three months. This procedure can be done more frequently if needed.

Do not walk on your spa cover or allow children to play on top of it. It is not designed for use as a safety device and is not intended to hold weight.

Decks

A deck or patio around your spa can add real beauty and enjoyment. Contact your local MORGAN sales representative for decking ideas and suggestions.

IMPORTANT NOTE: Be sure your patio has a slip resistant surface with adequate drainage. Check periodically for any signs of wear which may make these surfaces hazardous.

Protecting Your Spa In Winter Months

Cold climates, where the danger of freezing exists, require special care on your part in order

to prevent damage to the spa and equipment. One feature of the Digital Control System is that it has freeze protection built in. When water temperature falls below 40°F then the controller automatically activates the pumps to circulate the water. This is a normal spa function and no action on your part is necessary.

CAUTION: THE ABOVE WILL NOT WORK IF THERE IS A POWER FAILURE.

The only sure way to winterize your spa is to complete the following steps:

- Drain spa of all water.
- Run blower to clear air channels of water. Be sure pump and heater are not running.
- Remove any remaining water with a sponge.
- Remove drain plug from bottom of pump housing.
- Remove cartridge housing and cartridge filter, drain water and leave off.
- For the best protection, the power pack can be removed.
- If you cannot drain all of the water, especially from the air channels and the heater housing, a non-toxic anti-freeze, which can be purchased at any recreation vehicle supply center, should be added.

If power is to be out for a considerable length of time, it is advised that you contact your nearest sales location for instructions on how to minimize damage to your spa. We recommend that you use and enjoy your spa during the winter months. This takes the worry out of freezing temperatures and gives you twelve months of spa enjoyment.

Moving A Morgan Spa

Your MORGAN portable spa can be moved when you change your address or you simply want to change the location of the spa in your backyard. When moving a spa, care must be taken to block and level the spa at key bearing points. For this reason, MORGAN personnel must move your spa for the warranty to remain in force.

RELOCATION OF THE SPA BY PERSONS OTHER THAN MORGAN PERSONNEL VOIDS THE WARRANTY ON THE SPA.

SECTION 6 Chemicals

The Spa Frog Mineral Purifier for Spas

What Is It?

The Spa Frog Mineral Purifier is a do-it-yourself product (placed in the core of the filter cartridge) which sanitizes the water when used in conjunction with Morgan Chlorine or Morgan Bromine.

How It Works-

The Spa Frog Mineral Purifier works by performing three primary functions which taken together with Morgan Shock-Out assist in killing bacteria 24 hours per day. This results in safe, odor free, crystal clear, softer feeling water and at the same time reduces chemical use.

The Frog has a built-in reminder dial for easy to remember 4-month replacement.

Your Spa Frog has already been pre-installed in the core of the filter cartridge at the factory. You must remove the Spa Frog and set the 4-month reminder dial before start-up of the spa.

Spa Start-Up-

- Remove Frog from filter cartridge and set the reminder dial.
- Fill spa with water.
- Test the pH and total alkalinity with the Quick Dip test strips provided in your chemical start-up kit.
- Add Morgan Metal Protector and Stain Preventer. In areas with high calcium content, Morgan Stain and Scale Defense may also be needed.
- Adjust pH to 7.2 - 7.8 ppm, and adjust total alkalinity to 100 - 175.
- Shock spa to remove all contaminants following label instructions.
- Add either Morgan Chlorinating Granules or Morgan Spa Slow Dissolving Bromine Tab to .5 - 1 ppm.

Regular Spa Care



Run filtration system a minimum of 4 hours per day.



Regularly test water for pH, total alkalinity and chlorine or bromine levels.

Bromine
Chlorine

Maintain a .5 ppm chlorine or .5 ppm bromine level at all times.



Shock the spa with a dichlor or non-chlorine shock once a week or if water looks hazy.



Remember to replace SPA FROG and to drain and refill the spa every 3 to 4 months.

Your MORGAN spa is not like a swimming pool. On a much smaller scale the temperature and bather load are different. The water in the spa must be treated with chemicals to prevent the growth of bacteria and fungi and the transmission of diseases.

NEVER USE SWIMMING POOL CHEMICALS IN YOUR SPA.

IMPORTANT NOTE: DO NOT USE THE BAQUASPA CLEANING SYSTEM IN YOUR SPA. The Baquaspa Cleaning System can cause severe damage to your spa's plastic pvc plumbing.

WARNING - Do not store spa chemicals underneath spa cabinet. It is advised that they be stored in a locked cabinet away from the spa itself.

You should conscientiously follow the instructions provided concerning the chemical balance of the water in your spa. The following is a list of general tips on the use and storage of chemicals.

- Before using chemicals, **READ** the labels and directions carefully. Follow use instructions found on the labels.
- Keep all chemicals out of the reach of small children.

- Store your spa chemicals in a clean, cool, dry, well ventilated area preferably off the floor to prevent contamination from other materials.
- Always add the chemicals directly to the spa water. Chemicals should be broadcast across the surface of the water or diluted and poured into the water with the spa operating on "BLOWER ONLY."
- **NEVER** add chemicals to the spa while people are using it.
- Carefully clean up any spilled chemicals with large amounts of water to dilute and wash away the chemicals.
- Since the chemistry of spa tub water changes very quickly, test the water in your spa with a test kit on a daily basis. Add the necessary chemicals according to the test results and chemical manufacturer's instructions.

THE IMPORTANCE OF CHEMICAL BALANCE

Spa chemicals serve a variety of functions in your spa. They purify and disinfect the spa water and they also help to prevent mineral build-up and damage to your spa's equipment. **FAILURE TO MAINTAIN PROPER DISINFECTANT LEVEL AND pH BALANCE IN YOUR SPA AT ALL TIMES CAN CAUSE SEVERE PERMANENT DAMAGE TO YOUR SPA'S EQUIPMENT.** Please read the following paragraphs about spa chemical balance, and also read the MORGAN SPA MAINTENANCE GUIDE and be thoroughly familiar with it.

A SIMPLE OVERVIEW OF SPA CHEMISTRY AND DISINFECTING

The filtering action of your spa's equipment can effectively remove soil particles and other debris, but the addition of spa chemicals is required to disinfect your spa. Disinfecting can be accomplished by adding a germ-killing chemical, silver, which is contained in your Spa Frog Mineral Purifier, to the spa water in sufficient strength to provide nearly instantaneous destruction of bacteria.

The disinfecting agents plus strong oxidizers like MORGAN Shock-Out have properties which cause them to react with and destroy many foreign materials other than bacteria. Many of these materials, if not destroyed by oxidation, would impart undesirable characteristics to the water.

THE IMPORTANCE OF pH CONTROL

pH is one of the most important aspects of spa water chemistry, yet it is also the most misunderstood. Maintaining pH balance is important to the long life of your spa and to your personal comfort when using your spa. The relative acidity or alkalinity of water (pH) is measured on a scale of numbers ranging from 0 to 14. The mid-point of seven (7) is said to be precisely neutral, above which alkalinity becomes progressively greater.

Your spa water pH should always be maintained at a slightly alkaline condition of 7.2 or 7.6 on this scale. This level may be checked using chemical test strips which are available at your MORGAN store. Refer to the MORGAN SPA MAINTENANCE GUIDE for information on using these test strips.

From the viewpoint of health and sanitation, the most serious effect of improper pH control is reduced efficiency of the disinfecting process. As pH rises above 8.0, the sanitation residual progressively weakens to the point at which it may be virtually useless for disinfecting and oxidation purposes.

It can surprise the new spa owner to discover that serious water problems can develop despite the fact that the filters are functioning properly and disinfectant levels are testing at normal. In such cases, the problem can often be traced to the fact that the pH has been permitted to drift well into the undesirable zone above 7.6 or below 7.2.

NOTE

Read through the Morgan Spa Maintenance Guide thoroughly and follow the instructions given prior to using your spa.

Trouble Shooting Guide

PROBLEM	CAUSE	SOLUTION
Cloudy water	Inadequate filtration/dirty filter	Check to make sure the filter is running properly; clean filter with Morgan Rapid Filter Rinse.
	Excessive oils/organic matter	Shock the spa with Morgan Shock Out.
	Improper sanitation	Shock with Morgan Shock Out. Replace the Spa Frog Mineral Purifier if older than 4 months.
	High pH and/or high alkalinity	Adjust pH using Morgan pH Down.
	Suspended particles/organic matter	Use Morgan Shock Out.
	High total dissolved solids (TDS)	Depending on the severity--drain the spa to half and refill; or drain the spa completely, clean and refill.
	Over used or old water	Drain the spa, clean and refill.
	Precipitated calcium	Use Morgan Metal Protector.
Water odor	Excessive organics	Shock the spa with Morgan Shock Out.
	Improper sanitation	Shock with Morgan Shock Out. Replace the Spa Frog Mineral Purifier if older than 4 months.
	Inadequate filtration	Check to make sure the filter is operating properly, clean filter with Morgan Rapid Filter Rinse.
	Low pH	Raise pH with Morgan pH Up.
Musty odor	Bacterial or algae growth	Shock the spa with Morgan Shock Out. If problem visible, also drain, clean, refill and balance spa.
Eye irritation	Low pH	Raise pH with Morgan pH Up.
Foaming	Build up of body oils, lotion and chemicals resulting in soap or detergent	Add Morgan Foam Gone; or drain and refill.
	Over-used or old water	Drain and refill.
	Excessive organics	Shock with Morgan Shock Out.
	Improper sanitation	Shock with Morgan Shock Out. Replace the Spa Frog Mineral Purifier if older than 4 months.
Organic buildup	Body oils and dirt	Depending on severity--drain spa, use Morgan All Surface Cleaner to remove the scum, refill spa and adjust water.
	Inadequate filtration	Check to make sure the filter is operating properly. Clean filter with Morgan Rapid Filter Rinse. To clean the scum--drain spa, use Morgan All Surface Cleaner to remove scum, refill and adjust water.
Algae	High pH	Shock spa with Morgan Shock Out. Add Morgan pH Down.
	Insufficient sanitizing	Shock with Morgan Shock Out. Be sure the Spa Frog Mineral Purifier is less than 4 months old. Replace if necessary.
Skin irritation	Unsanitary/polluted water	Shock with Morgan Shock Out. Replace the Spa Frog Mineral Purifier if older than 4 months.
	Soaking too long	Soak for smaller intervals, such as 15 minutes.
	Water temperature too high	Reduce water temperature.
Stains	pH or total alkalinity too low	Adjust pH with Morgan pH Up and adjust alkalinity using Morgan Alkalinity Increaser; use Morgan Metal Protector; drain and clean spa.
	High iron or copper in water source	Use Morgan Metal Protector; adjust water.
Scale	Too much calcium dissolved in water--pH and total alkalinity too high	Use Morgan Metal Protector; adjust alkalinity using Morgan pH Down. With concentrated scale deposits--drain the spa, scrub the scale off, refill the spa and balance the water.

SECTION 7

Ozonators

Sanitizing With Ozone

Your spa has an option of having an ozone generator installed. The use of ozone in addition to normal spa sanitizing will significantly reduce the amount of chemicals used.

SOME OF THE BENEFITS OF USING OZONE

- It kills all known bacteria and viruses found in spas, hot tubs, and pools quickly and effectively.
- It is inexpensive and automatic.
- It does not discolor hair, fade swimsuits, or cause dry skin.
- It does not irritate eyes or skin.
- It is safe for your spa and equipment.
- It eliminates cloudy water.
- It will not adversely affect the pH.
- It eliminates chlorine and bromine by-products.
- It is environmentally safe.
- It makes your water sparkle.

Spa Maintenance With Ozone

Ozone is a very effective natural water purifier that is lethal to bacteria, viruses, and contaminants without harming people and equipment. There are just a few "Rules of Thumb" that you should follow. Take the time to learn these simple rules and you will have no trouble maintaining a clear, clean spa that will provide you with years of enjoyment.

Always maintain the following spa water operating parameters:

Total Alkalinity: 80 to 120 ppm
pH: 7.2 to 7.6

- Operate your spa Filtration Cycle for the minimum time according to the following chart. *Note:* Ozone is only produced in filtration mode. Also, spa conditions can vary due to location and bathing load - adjust accordingly.

Gallons	Operating Time Per Day
Up to 250	4 to 6 hours
251 - 500	8 to 10 hours
Over 500	12 to 18 hours

- Total alkalinity is very important. If the spa water's total alkalinity is too low, the pH can change rapidly and maintaining the proper pH level will be difficult. Equipment will become corroded if the total alkalinity is too low. If the total alkalinity is too high, it will be very difficult to adjust the pH. In addition, scale will form on the walls of the spa and in the equipment if the total alkalinity is too high. The water's total alkalinity should be adjusted to the proper level BEFORE adjusting the pH. Check total alkalinity once a week and adjust to proper levels as necessary.
- Ozone does not have an effect on the spa water's pH. Bathers will have the most effect on the pH. It is therefore necessary to check the pH of your spa water twice a week and adjust it to the proper level.
- Follow the recipe for your Nature 2 Spa Purifier. Refer to Section 6 for information about the Nature 2 Purifier.
- Filtration is critical to proper ozone operation and water purity. Because ozone purifies the water so completely, the filter gets dirty fast. Clean the filter properly and often. It is a good idea to have an extra filter cartridge handy so you can take the time to clean the filter properly and thoroughly. Algae, suntan oil, body oils, and other personal care products can form a coating on the cartridge surface that may not be removed thoroughly by rinsing with a hose. We recommend spraying the filter with MORGAN Rapid Filter Rinse. Carefully replace the cartridge element over the rod making sure it seats properly. It is important that all the filter seals and gaskets are in their proper positions. If the filter is not sealed properly, it cannot do its job. Inspect the filter cartridge and housing regularly. Bad gaskets or loose or cracked filter housing can result in cloudy and unpleasant smelling water.
- After heavy use (more than 2 people in the spa for longer than half an hour), the spa should be "shocked" with Morgan Shock Out treatment to rid the water of the extra contamination.

- If the pH is too high (over 7.6) or too low (under 7.2), the water may look cloudy or green. The water may also be irritating to the eyes. High or low pH can also cause damage to the spa's equipment or scale build-up on the spa walls and plumbing.
- Drain your spa completely, at least every 4 months.

Ozonator Trouble Shooting Guide

SYMPTOM	PROBABLE CAUSE	CORRECTIVE ACTION
Indicator light on the control panel is not on.	No power to ozone generator	Check power source.
	Broken or defective generator cartridge	Replace generator cartridge
Cloudy water condition even though the ozone generator appears to be operating properly	Recent startup with new water	Operate in filtration mode for a minimum of 24 hours.
	Total alkalinity out of balance	Balance total alkalinity to 80-120 ppm.
	pH out of balance	Balance pH to 7.2 - 7.6
	Lack of filtration	Clean filter, check for cracks in filter, increase filtration time.
	Trace metals in water	Add Metal Remover.
	Organic micro-debris in the water	Operate ozone generator longer or add Morgan Shock Out as per Nature 2 recipe.
	Too much clarifer added	Don't add anymore, operate filter and skim excess clarifer off surface of water.

If water is still cloudy after addressing all of the above, go back and recheck--you probably missed something.

My water looks clear but smells bad	Trace metals in water	Add Metal Remover.
	pH out of control	Balance pH to 7.2 - 7.6
	Not enough oxidizer	Operate ozonator longer or add Morgan Shock Out.
My pH bounces up and down like a yo-yo	Total alkalinity out of balance	Balance total alkalinity to 80-120 ppm.
	Trace metals in water	Add Metal Remover.

SECTION 8

Glossary of Terms

2-SPEED PUMP	The engine of the spa which draws water from the main drain and skimmer, pushes it through the filter and heater, and returns it through the spa jets.
ADJUSTABLE AIR BLOWER	Allows for adjusting different levels of blower performance.
AIR ACTION JET	This jet is powered by air and gives a bubbling action.
AIR INJECTOR JET	This jet is powered by air and gives a unique bubbling sensation action.
AUXILIARY CONTROL	Allows operation of the spa function from the opposite side of the spa.
CYCLONE JETS	It gives a truly remarkable and powerful massage by boasting a 360° circular motion and can be adjusted for pressure and direction.
DIGITAL CONTROL CENTER	The control center used to display the temperature and program the spa.
FILTER	The filter cleans the spa by removing debris and impurities from the water.
FLUTTER BLASTER JETS	Flutter spinning motion gives a unique and pleasurable massaging sensation. Jets can be easily adjusted for water flow necessary for effective hydrotherapy.
GFCI	A safety device that protects against electrical shock should a malfunction in the equipment pack occur.
HEATER	A heater element in a stainless steel housing used to heat the water to a desired setting.
LIGHT	A safe 12 volt light.
MAIN DRAIN / SUCTION	The lower suction fitting on the bottom of the spa that returns water to the pump and filter.
MASTER MASSAGE JET	An 18" jet with 14 orifices that are controlled by a diverter valve to get a full flow and create a whirlpool action or to divert some water flow away from the jet to customize your own therapeutic needs.
MINI FLUTTER BLASTER JETS	Unique flutter action that provides tingling sensations similar to the large Flutter Blaster. Great adjustability helps you select the hydrotherapy that fits.

MINI LUXURY JETS	Gives massaging action similar to the full size Luxury Jet but with a smaller plume of water. Range of adjustability helps you customize your hydro-therapy.
NECK JETS	The ultimate neck massage. The jet is located out of the water, flow goes directly onto the body for greater hydrotherapy. Nozzle is multi-directional and is easily adjusted.
NON-ADJUSTABLE DIRECTIONAL EURO JET & OZONE JET	This jet has a unique soft-massaging action. By moving the nozzle in the center you can adjust the direction of the jet water flow. This jet also serves as the entry point for your ozonator output.
NON-ADJUSTABLE PULSATOR EURO JET	This jet has a unique spinning motion with a soft-massaging action.
OZONE (FOOT) JETS	This jet is the entry point for your ozonator output and also has strong massaging action that is ideally positioned for the feet.
POWER COLLAR VALVE	This valve increases or decreases the water velocity to the mini-luxury jets in the power collar area.
SKIMMER / BOX SKIMMER	Rectangular outlet at water level. The skimmer removes surface water to filter out body oils and floating debris from the top of the water.
SWIRLPOOL JETS	Diverts most of the water flow to create a whirlpool effect.
TOTAL TURBO VALVE	This valve allows you to direct air to enjoy a powerful massage, or a bubbling sensation, or both.
ULTRAMASSAGE LUXURY JETS	Therapeutic jets that allow you to adjust water flow and direction.
WATERFLOW CONTROL VALVE	This valve is used to increase or decrease the water CONTROL VALVE pressure flow to the neck jets or the mini luxury jets.

KEYPAD WITH DISPLAY
KEYPAD WITHOUT DISPLAY (CABLE IS REQUIRED)
TEMPERATURE PROBE



PUMP #1 CONNECTOR (LEFT SIDE OF THE ENCLOSURE)

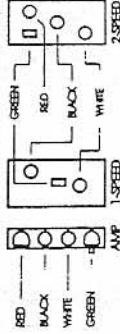

VOLTAGE	240V
GREEN / GROUND	P34
RED / LOW SPEED	P13
BLACK / HIGH SPEED	P14
WHITE / COM	P15

PUMP #2 CONNECTOR (LEFT SIDE OF THE ENCLOSURE)

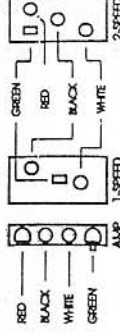

VOLTAGE	240V
GREEN / GROUND	P32
RED / LOW SPEED	P16
BLACK / HIGH SPEED	P17
WHITE / COM	P18

LIGHT CONNECTOR 24 W MAX. (LEFT SIDE OF THE ENCLOSURE)

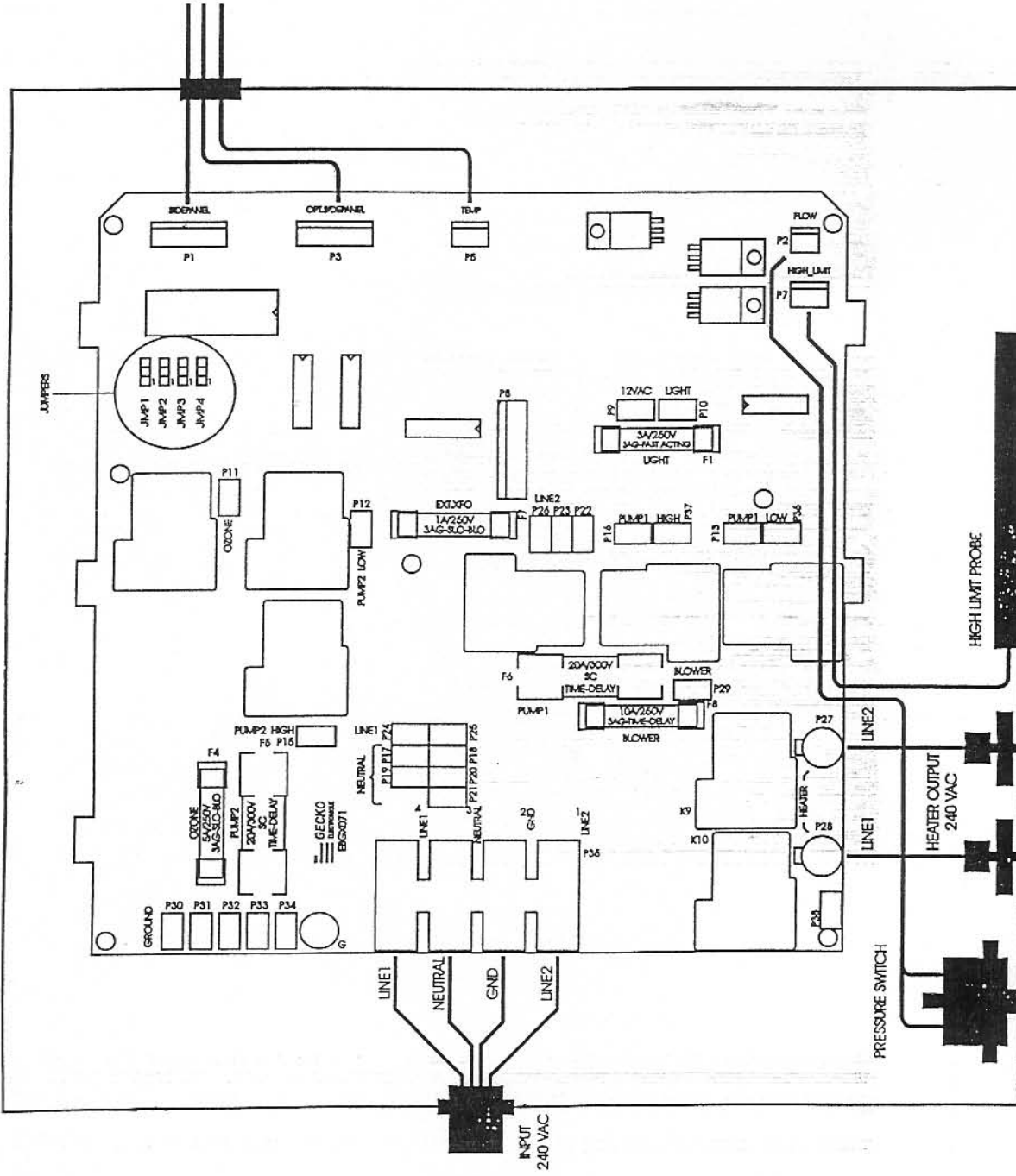
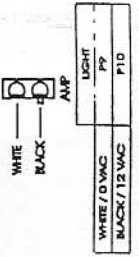

BLOWER CONNECTOR (LEFT SIDE OF THE ENCLOSURE)

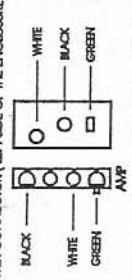

VOLTAGE	240V
GREEN / GROUND	P33
BLACK / LINE	P29
WHITE / COM	P28

COOLING CONNECTOR (LEFT SIDE OF THE ENCLOSURE)

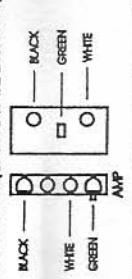

VOLTAGE	120V
GREEN / GROUND	P31
BLACK / LINE	P11
WHITE / COM	P19

CIRCULATION PUMP CONNECTOR (LEFT SIDE OF THE ENCLOSURE)

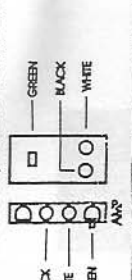

VOLTAGE	240V
GREEN / GROUND	P35
BLACK / LINE	P12
WHITE / COM	P11

Single Pump / Dual Pump 240 Convertible

GECKO 120 /240 CONVERTIBLE PACK

PUMP #1 CONNECTOR

VOLTAGE	120V
GREEN / GROUND	P4
BLACK / LOW SPEED	P14
RED / HIGH SPEED	P12
WHITE / COM	P8

BLOWER CONNECTOR

VOLTAGE	120V
GREEN / GROUND	P6
BLACK / LINE	P11
WHITE / NEUTRAL	P9

OZONE CONNECTOR

VOLTAGE	120V
GREEN / GROUND	P5
BLACK / LINE	P16
WHITE / NEUTRAL	P8

LIGHT CONNECTOR

WHITE / 0 VAC	P23
BLACK / 12 VAC	P22

PRESSURE SWITCH

(GREEN)	P25
(RED)	P24

HEATER 240V

BLACK 1	P20
BLACK 2	P21

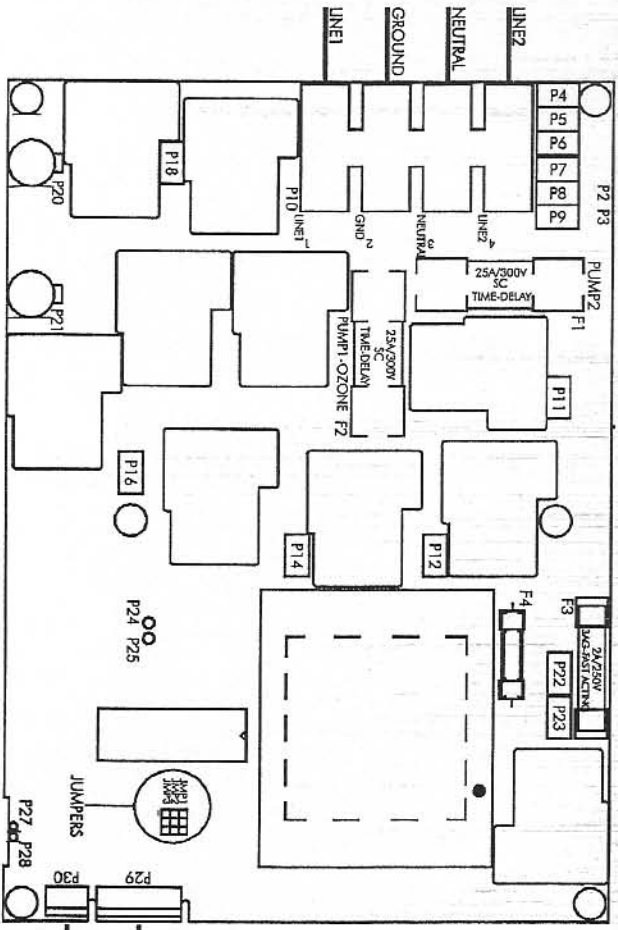



 SSPA-1-P12-B1-O1-L-S-JM-MG1
 3962-01C
1-800-78-GECKO



JUMPER SETTINGS

JAMP1 = HC MODE = LC MODE
 JAMP2 = °F UNITS = °C UNITS
 JAMP3 = SINGLE PUMP = DUAL PUMP

USE COPPER CONDUCTORS ONLY. FOR SUPPLY CONNECTIONS, USE CONDUCTORS SIZED ON THE BASIS OF 60°C AMPACITY BUT RATED MINIMUM 90°C.

GECKO 220V PACK NO BLOWER

PUMP #1 CONNECTOR

VOLTAGE	120V
GREEN / GROUND	P4
BLACK / LOW SPEED	P14
RED / HIGH SPEED	P12
WHITE / COM	P8

OZONE CONNECTOR

VOLTAGE	120V
GREEN / GROUND	P5
BLACK / LINE	P16
WHITE / NEUTRAL	P8

LIGHT CONNECTOR

	LIGHT
WHITE / 0 VAC	P23
BLACK / 12 VAC	P22

PRESSURE SWITCH

(GREEN)	P25
(RED)	P24

HEATER 240V

BLACK 1	P20
BLACK 2	P21

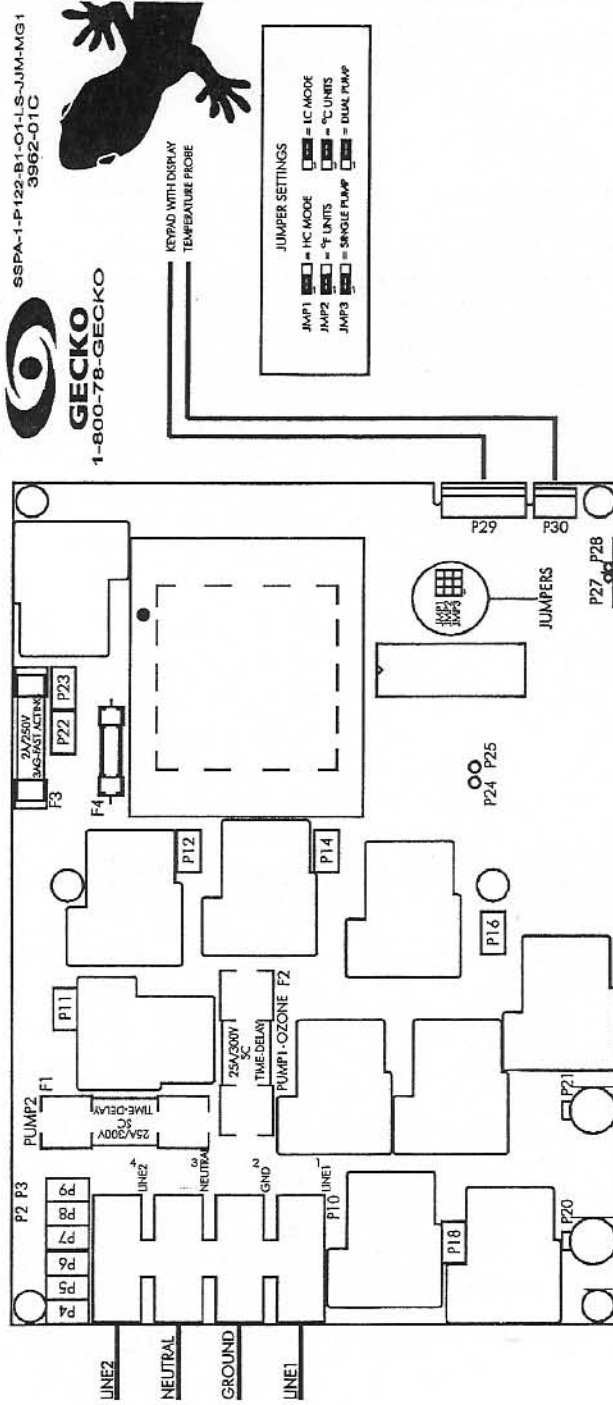

SSPA-1-P122-B1-01-LS-JJM-MG1
3992-01C

GECKO
1-800-78-GECKO



KEYPAD WITH DISPLAY
TEMPERATURE PROBE

JUMPER SETTINGS

JMP1 = HC MODE = °C UNITS = °F UNITS = DUAL PUMP

JMP2 = °C UNITS = °F UNITS = SINGLE PUMP

JMP3 = °C UNITS = °F UNITS = DUAL PUMP